



# Seat Fireblocking Checklist

Flammability Testing & Certification

## Step 1: General Information

Please enter all the general information and aircraft fields below. All fields are required.

<b>COMPANY NAME</b>	<b>CONTACT NAME</b>	<b>PHONE</b>
<b>FAX</b>	<b>EMAIL</b>	<b>DATE SENT</b>
<b>PUCHASE ORDER</b>	<b>AIRCRAFT COMPLETION DATE</b>	

## Aircraft Information

<b>AIRCRAFT MAKE</b>	<b>AIRCRAFT MODEL</b>
<b>AIRCRAFT SERIAL NUMBER</b>	<b>AIRCRAFT TAIL NUMBER</b>

## Step 2: Testing & Fabrication

Please enter all the testing and fabrication fields below. All fields are required.

**DOES SKANDIA HAVE YOUR PERMISSION TO FABRICATE TEST SPECIMENS AND ISSUE FAA 8130-9 FORMS ON YOUR BEHALF?**

Yes      No

<b>TEST DATA IS IN SUPPORT OF:</b>	<b>FAA PROJECT #</b>
Field Approval	
Major Repair & Alteration	
Minor Repair & Alteration	
Supplemental Type Certificate (STC)	
Type Certificate (TC)	
Technical Standard Order (TSO)	
Organization Designation Authorization (ODA)	
Other	



# Seat Fireblocking Checklist

Flammability Testing & Certification

## Step 3: Seat Information

What configuration in the aircraft are being added or modified?

### SEAT CONFIGURATION

Enter the number of seats for each category

**SINGLE PASSENGER**

**DOUBLE PASSENGER**

**DIVANS**

**LAV SEAT**

**JUMP SEAT/FLIGHT  
ATTENDANT SEAT(FAS)**

### ARE SEATS NEW OR EXISTING IN THE AIRCRAFT?

New

Existing

## Step 4: Seat Upholstery

Aircraft seats are manufactured to either an aircraft Type Certificate or to a TSO. Re-upholstery of a seat can affect its certification basis. The modifier of the seats should check with either the Type Certificate or the TSO holder before re-upholstering the seats. The modifier may be required to do additional testing or gain additional approvals to maintain airworthiness approval

### SEAT MANUFACTURER

### ARE THE SEATS BEING TESTED PER

Type Certificate

TSO C-39B (9g)

TSO C-127A (16g)

### SEAT PART NUMBERS

If seats are being tested to 14 CFR 25.853 (C) in support of TSO C-127a, we will then need the following information: (for 16g seats only).

### SEAT PART NUMBERS

### SEAT SERIAL NUMBERS



# Seat Fireblocking Checklist

Flammability Testing & Certification

---

**SEAT PART NUMBERS** (CONTINUED)

**SEAT SERIAL NUMBERS** (CONTINUED)



# Seat Fireblocking Checklist

Flammability Testing & Certification

## Step 5: Seat Composite Tests

All aircraft seats require flammability testing for all components of the seat (armrest, shrouds, close-out, drawers, etc.) tested in the “as installed state” per 14 CFR 25.853 (a).

All components of a seat must also meet the requirements of 14 CFR 25.853 (a)(ii) 12-second vertical burn test as a composite representing the actual build-up. Skandia can perform this additional testing.

1. Copies of **INVOICES OR PACKING LISTS** providing traceability for all fabricating components including panels (Nomex, wood, aluminum, fiberglass, etc.), laminates, veneers, foam, finishes, poly coats, leather, fabric, vinyl, mirror, adhesives, flame retardants/treatments and all other materials used in production.
2. Sketch, production drawing or Composite Panel Production Build-up form of each different production assembly.
3. Original FAA form 8130-9 for each set of fabricated test specimens submitted.
4. Vertical Burn Test, 12 second: Three (3) panels fabricated to represent production usage; panels must be 3” x 12”. If panels have a woven surface (i.e., fabric, carpet, etc.), three panels each of both warp and fill are required.
5. Provide substructure material information. (What is the armrest or wrap around, etc. structure made of?)

### ARMRESTS

Yes      No

### SEAT SHROUDS

Yes      No

### SEAT BASE

Yes      No

### IS SKANDIA FABRICATING THE ARMRESTS?

Yes      No

### IS SKANDIA FABRICATING THE SEAT SHROUDS?

Yes      No

### IS SKANDIA FABRICATING THE SEAT BASE?

Yes      No



# Seat Fireblocking Checklist

Flammability Testing & Certification

## Step 6: Items required to complete fireblocking

Test plan process does not begin until all materials and paperwork have been received. Dress cover material is needed for each fireblock test. In some cases, we may have to perform multiple tests with the same dress cover material.

1. Copies of **INVOICES OR PACKING LISTS** providing traceability for all fabricating components used in production including: dress cover(s), foam(s), glue, thread, fastener, muslin, canvas, batting, and all other materials used in production cushion assembly.
2. Sketch or production drawing of each different cushion assembly.
3. For each different dress cover or cushion buildup:
  - **Leather:** 75 square feet; or 12 pieces cut 32"x32"; or 85 sq. ft. window pane with leather close-out; or 80 sq. ft. fully encapsulated with 2" hook and loop
  - **Fabric:** 40" – 48" 6 yards; 49" – 53" 5 yards; 54" – or more 4 yards. Add ½ yard more of additional fabric for window pane dress cover close-out.
  - **Oil Burn:** All materials for oil burn must pass a vertical burn test. If you are supplying materials for an oil burn test, please provide enough material for the vertical burn test.
4. Extra leather or fabric may be required for composite panel testing.
5. Please Note - Testing combination dress covers as 50/50 is worse case scenario

## Additional charges will be assessed for receiving scrap pieces.

### IS PADDING OR BATTING/MUSLIN USED ON SEATING SURFACES?

Yes      No

### IF SO, HOW IS IT HELD IN PLACE?

- Glued
- Placed
- Stitched at Seams
- Quilted to Dress cover

### IF FIREBLOCKING MATERIAL IS BEING USED, HOW IS IT USED?

- Glued on seating surface only
- Placed on seating surface only
- Fully Encapsulated with stitched seams
- Fully Encapsulated with glued seams
- Fully Encapsulated and bonded to foam

***You may be required to send a small quantity of your adhesive if it is not stocked at Skandia.  
We will make every effort to stock your glue.***

## Step 7: Seam Closure

See example images and enter corresponding number on next page.

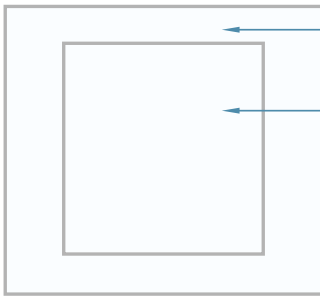
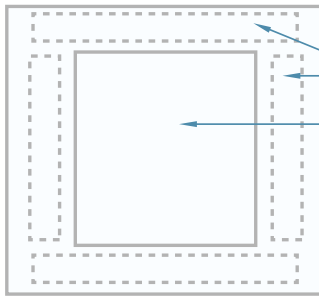
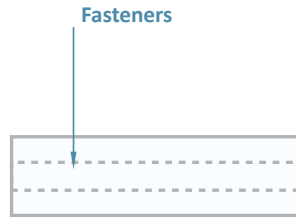
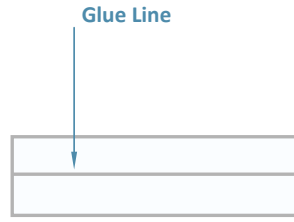
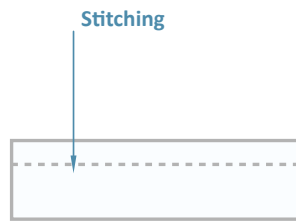
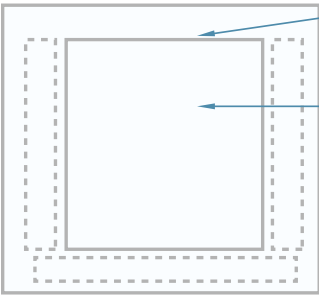
<p><b>Glued Window Pane #1</b></p>  <p>Dress Cover</p> <p>Close out Material</p> <p>Black view of back or bottom cushion. Dress cover bonds to a close out in window pane style with adhesive.</p>	<p><b>Fastened Window Pane #2</b></p>  <p>Dress Cover</p> <p>Fasteners</p> <p>Close out Material</p> <p>Black view of back or bottom cushion. Dress cover fastens to the close out in window pane style.</p>
<p><b>Fastened Side Seam #3</b> End view</p>  <p>Fasteners</p>	<p><b>Glued Side Seam #4</b> End View</p>  <p>Glue Line</p>
<p><b>Stitched Side Seam #5</b> End View</p>  <p>Stitching</p>	<p><b>Flap Closure #6</b></p>  <p>Stitching</p> <p>Flap</p> <p>Dress Cover stitched on one side with remaining three sides bonded or fastened.</p>



# Seat Fireblocking Checklist

Flammability Testing & Certification

## Step 7: Seam Closure - continued

See example images and enter corresponding number on next page.

### SINGLE PASSENGER SEAT SEAM CLOSURE:

BACK Bottom If "window pane", what is the close-out material?

### DOUBLE PASSENGER SEAT SEAM CLOSURE:

BACK Bottom If "window pane", what is the close-out material?

### DIVAN SEAT SEAM CLOSURE:

BACK Bottom If "window pane", what is the close-out material?

### LAV SEAT SEAM CLOSURE:

BACK Bottom If "window pane", what is the close-out material?

### JUMP-SEAT /FAS SEAM CLOSURE:

BACK Bottom If "window pane", what is the close-out material?

### HEADREST SEAM CLOSURE:

If "window pane", what is the close-out material?

### LEGREST/FOOTREST SEAM CLOSURE:

If "window pane", what is the close-out material?



# Seat Fireblocking Checklist

Flammability Testing & Certification

## Step 8: Matrix for Production Articles

This section of the form deals with production information. Fill in vendors and part numbers, then select the appropriate box for each specimen with an X.

### DRESS COVER

Vendor		Part #					Invoices or packing slips enclosed?
Pax Seats	Divan	Jump Seat/ FAS	Lav Seat	Head Rest	Foot Rest	Flame Treatment	

### DRESS COVER

Vendor		Part #					Invoices or packing slips enclosed?
Pax Seats	Divan	Jump Seat/ FAS	Lav Seat	Head Rest	Foot Rest	Flame Treatment	

### DRESS COVER

Vendor		Part #					Invoices or packing slips enclosed?
Pax Seats	Divan	Jump Seat/ FAS	Lav Seat	Head Rest	Foot Rest	Flame Treatment	

### FOAM

Vendor		Part #					Invoices or packing slips enclosed?
Pax Seats	Divan	Jump Seat/ FAS	Lav Seat	Head Rest	Foot Rest	Flame Treatment	

### FOAM

Vendor		Part #					Invoices or packing slips enclosed?
Pax Seats	Divan	Jump Seat/ FAS	Lav Seat	Head Rest	Foot Rest	Flame Treatment	

### FOAM

Vendor		Part #					Invoices or packing slips enclosed?
Pax Seats	Divan	Jump Seat/ FAS	Lav Seat	Head Rest	Foot Rest	Flame Treatment	





# Seat Fireblocking Checklist

Flammability Testing & Certification

## Step 8: Matrix for Production Articles - continued

This section of the form deals with production information. Fill in vendors and part numbers, then select the appropriate box for each specimen with an X.

### SCRIM-BACKED FOAM

Vendor	Part #						Invoices or packing slips enclosed?
Pax Seats	Divan	Jump Seat/ FAS	Lav Seat	Head Rest	Foot Rest	Flame Treatment	

### BATTING

Vendor	Part #						Invoices or packing slips enclosed?
Pax Seats	Divan	Jump Seat/ FAS	Lav Seat	Head Rest	Foot Rest	Flame Treatment	

### MUSLIN

Vendor	Part #						Invoices or packing slips enclosed?
Pax Seats	Divan	Jump Seat/ FAS	Lav Seat	Head Rest	Foot Rest	Flame Treatment	

### FIRE-BLOCKER

Vendor	Part #						Invoices or packing slips enclosed?
Pax Seats	Divan	Jump Seat/ FAS	Lav Seat	Head Rest	Foot Rest	Flame Treatment	

### ADHESIVE

Vendor	Part #						Invoices or packing slips enclosed?
Pax Seats	Divan	Jump Seat/ FAS	Lav Seat	Head Rest	Foot Rest	Flame Treatment	

### FASTENER

Vendor	Part #						Invoices or packing slips enclosed?
Pax Seats	Divan	Jump Seat/ FAS	Lav Seat	Head Rest	Foot Rest	Flame Treatment	



# Seat Fireblocking Checklist

Flammability Testing & Certification

## Step 8: Matrix for Production Articles - continued

This section of the form deals with production information. Fill in vendors and part numbers, then select the appropriate box for each specimen with an X.

### FASTENER

Vendor		Part #					Invoices or packing slips enclosed?	
Pax Seats	Divan	Jump Seat/ FAS	Lav Seat	Head Rest	Foot Rest	Flame Treatment		

### CLOSE-OUT FABRIC

Vendor		Part #					Invoices or packing slips enclosed?	
Pax Seats	Divan	Jump Seat/ FAS	Lav Seat	Head Rest	Foot Rest	Flame Treatment		

### ADHESIVE FASTENER

Vendor		Part #					Invoices or packing slips enclosed?	
Pax Seats	Divan	Jump Seat/ FAS	Lav Seat	Head Rest	Foot Rest	Flame Treatment		

### OTHER

Vendor		Part #					Invoices or packing slips enclosed?	
Pax Seats	Divan	Jump Seat/ FAS	Lav Seat	Head Rest	Foot Rest	Flame Treatment		

Item Material

### OTHER

Vendor		Part #					Invoices or packing slips enclosed?	
Pax Seats	Divan	Jump Seat/ FAS	Lav Seat	Head Rest	Foot Rest	Flame Treatment		

Item Material

### COMMENTS

## Step 9: Production Cushion Build-Up

Window Pane is a type of close-out where the dress cover wraps around to the bottom or back of the cushion and a separate piece of material, which may be the same as the dress cover or different, closes out the cushion by sewing, gluing or use of hook and loop fastener. **Complete one sheet for each different cushion build-up.**

### SELECT PRODUCTION CUSHION BUILD-UP TO BE TESTED

- |               |               |
|---------------|---------------|
| Single Back   | Divan Bottom  |
| Single Bottom | Headrest      |
| Double Back   | Jump seat/FAS |
| Double Bottom | Lav           |
| Divan Back    | Legrest       |

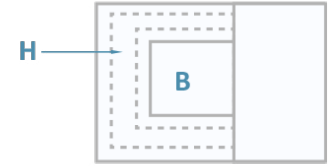
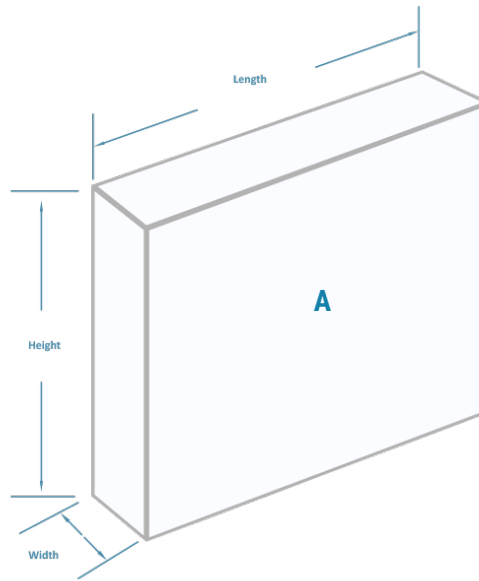

For Window Pane Close-outs

### AIRCRAFT S/N

### ARE THE DIMENSIONS IN INCHES OR MILLIMETERS?

Inches      Millimeters

Material	Manufacturer	Part Number	Length	Height	Width
A Dress Cover					
B Close-out Material					
C Foam					
D Foam					
E Foam					
F Foam					
G Foam					
H Hook Fastener					
H Loop Fastener					
F Muslin					
G Nylon Pack Cloth					
H Batting					
I Aluminum/Honeycomb/Other Stiffener					
J					
K					
L					

\*J, K, & L lines are for other materials not listed

## Step 10: Divan Composite Panel Production Buildup

Please list all materials used in production including substrates and adhesives. The information provided will be used for composite panel testing. Please include part number and thickness of materials.

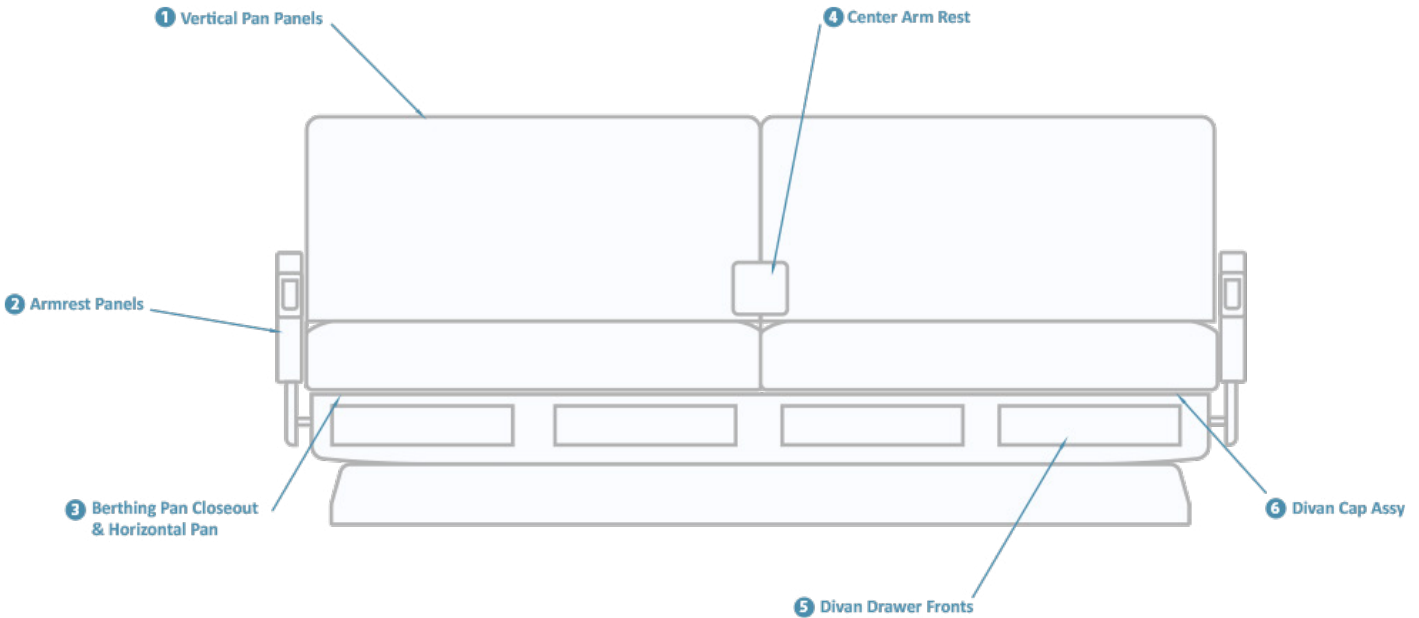

**1: VERTICAL PAN PANELS**

**2: ARMREST PANELS**

**3: BERTHING PAN CLOSEOUT & HORIZONTAL PAN**

**4: CENTER ARM REST**

**5: DIVAN DRAWER FRONTS**

**6: DIVAN CAP ASSEMBLY**

## DRESS COVERING

## Step 11: Single Seat Composite Panel Production Buildup

Please list all materials used in production including substrates and adhesives. The information provided will be used for composite panel testing. Please include part numbers and thickness of materials.

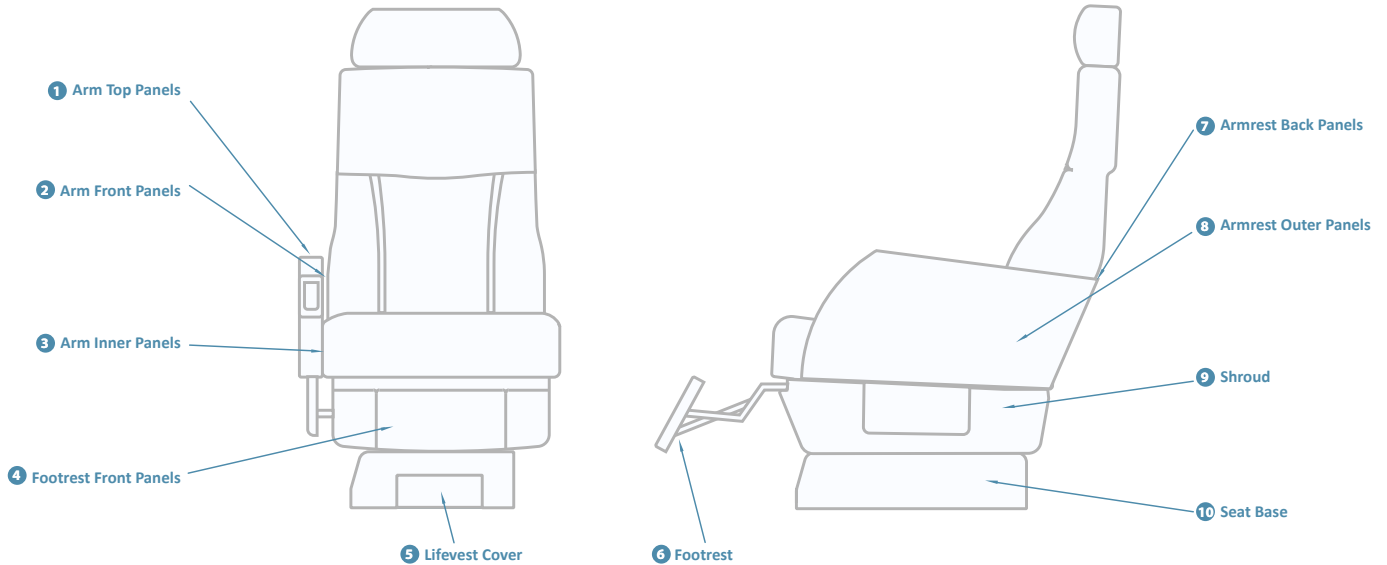

**1: ARM TOP PANELS**

**2: ARM FRONT PANELS**

**3: ARM INNER PANELS**

**4: FOOTREST FRONT PANEL**

**5: LIFEVEST COVER**

**6: FOOTREST**



# Seat Fireblocking Checklist

Flammability Testing & Certification

---

## Step 11: Single Seat Composite Panel Production Buildup - continued

Please list all materials used in production including substrates and adhesives. The information provided will be used for composite panel testing.

**7: ARMREST BACK PANELS**

**8: ARMREST OUTER PANELS**

**9: SHROUD**

**10: SEAT BASE**

**DRESS COVERING**

## Step 12: Double Seat Composite Panel Production Buildup

Please list all materials used in production including substrates adhesives. The information provided will be used for composite panel testing. Please include part numbers and thickness of materials.

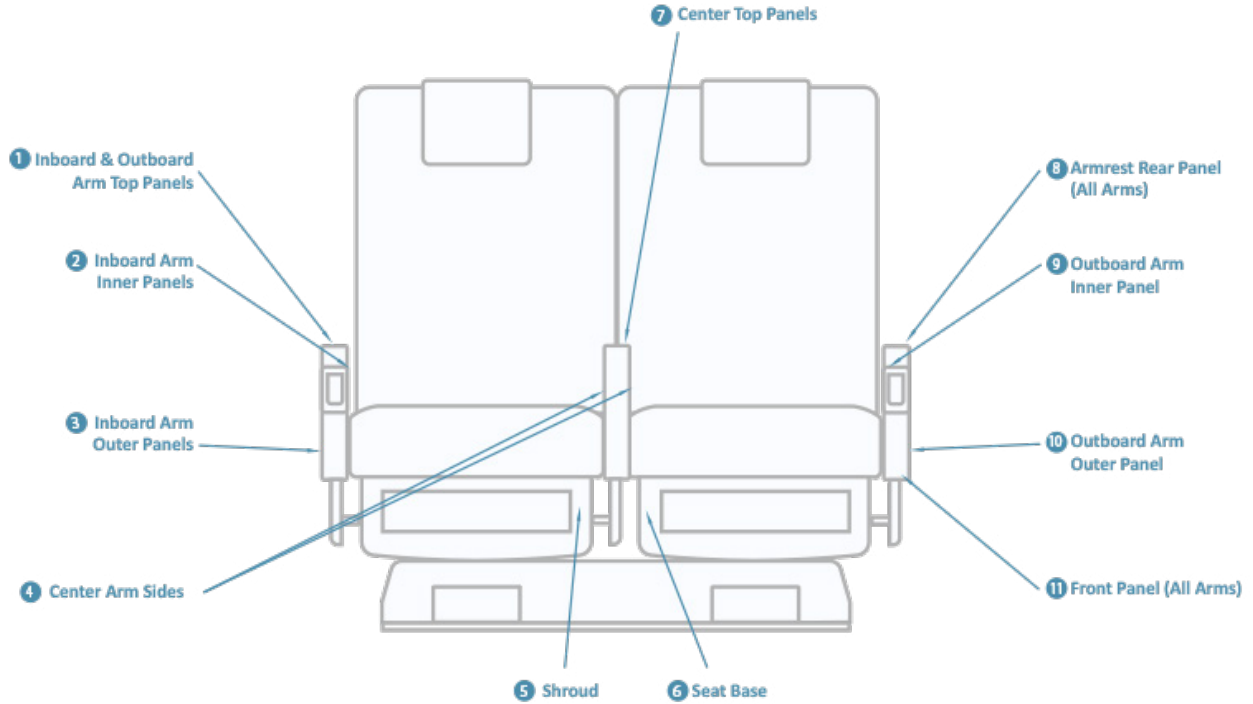

**1: INBOARD & OUTBOARD ARM TOP PANELS**

**2: INBOARD ARM INNER PANELS**

**3: INBOARD ARM OUTER PANELS**

**4: CENTER ARM SIDES**

**5: SHROUD**

**6: SEAT BASE**



# Seat Fireblocking Checklist

Flammability Testing & Certification

---

## Step 12: Double Seat Composite Panel Production Buildup - continued

Please list all materials used in production including substrates and adhesives. The information provided will be used for composite panel testing.

**7: ARMREST BACK PANELS**

**8: ARMREST REAR PANEL**

**9: OUTBOARD ARM INNER PANEL**

**10: OUTBOARD ARM OUTER PANEL**

**11: FRONT PANEL**

**DRESS COVERING**