



# 16G Replacement Dress Cover Checklist

Flammability Testing & Certification

## Step 1: General Information

Please enter all the general information and aircraft fields below. All fields are required.

**COMPANY NAME**

**CONTACT NAME**

**PHONE**

**FAX**

**EMAIL**

**AIRCRAFT COMPLETION DATE**

**PUCHASE ORDER**

## Aircraft Information

**AIRCRAFT MAKE**

**AIRCRAFT MODEL**

**AIRCRAFT SERIAL NUMBER**

**AIRCRAFT TAIL NUMBER**

**DOES SKANDIA HAVE YOUR PERMISSION TO FABRICATE TEST SPECIMENS AND ISSUE FAA 8130-9 FORMS ON YOUR BEHALF?**

Yes No

**IS TEST DATA IN SUPPORT OF AC 25-25B TSO MODIFICATION?**

Yes No

**DOES THE SEAT CURRENTLY HAVE MODIFICATION TAG(S) INSTALLED NEXT TO THE TSO TAG?**

Yes No If yes, please include a current picture of modification tag(s).

## Step 2: Testing & Fabrication

Please enter all the testing and fabrication fields below. All fields are required.

**SINGLE PASSENGER SEATS**

**DOUBLE PASSENGER SEATS**

**DIVANS**

**LAV SEATS**

**JUMPSEATS**

**CREW SEATS**



# 16G Replacement Dress Cover Checklist

Flammability Testing & Certification

### Step 3: Dress Cover Replacement

Re-upholstery of a seat can affect its certification basis. The modifier may be required to do additional testing or gain additional approvals to maintain airworthiness approval.

\*All aircraft seats require flammability testing for all components of the seat (armrest, shrouds, close-out, drawers, etc.) tested in the “as installed state” per 14 CFR 25.853(a).

#### SEAT MANUFACTURER

SEAT COMPOSITE TESTS	TO BE TESTED?		IS SKANDIA FABRICATING?	
	Yes	No	Yes	No
ARMRESTS				
SEAT SHROUDS				
SEAT BASE				

### Step 4: Seat Part Numbers

Please list out the seat part and serial numbers for each seat on the aircraft.

SEAT PART NUMBERS	SEAT LOCATION	SEAT SERIAL NUMBERS
-------------------	---------------	---------------------



# 16G Replacement Dress Cover Checklist

Flammability Testing & Certification

## Step 4: Seat Part Numbers - continued

Please list out the seat part and serial numbers for each seat on the aircraft.

**SEAT PART NUMBERS** (CONTINUED)

**SEAT SERIAL NUMBERS** (CONTINUED)

## Step 5: Items Required to Complete Fire-Blocking

Test plan process does not begin until all materials and paperwork have been received.

Copies of **INVOICES OR PACKING LISTS** providing traceability for all fabricating components used in production including: dress cover(s), foam(s), glue, thread, fastener, muslin, canvas, batting, and all other materials used in production cushion assembly.

Please take pictures of each different cushion assembly: backs, bottoms, headrests, legrests/footrests, and armrests. Include dimensions and armrest buildups on steps 8-17 of this checklist. It is very important to simulate the placement of any hook and loop attachment strips that may attach either back or bottom assemblies to the seat frame. Please make sure these are included.

For each different dress cover or cushion buildup:

**Leather:**

- 75 square feet; or 12 pieces cut 32"x32"; or
- 85 sq. ft. window pane with leather close-out; or
- 80 sq. ft. fully encapsulated with 2" hook and loop

**Fabric:**

- 40" – 48", 6 yards
- 49" – 53", 5 yards
- 54" – or more, 4 yards

**Oil Burn:** All materials for oil burn must pass a vertical burn test. If you are supplying materials for an oil burn test, please provide enough material for the vertical burn test.

**Additional charges will be assessed for receiving scrap pieces.**

PLEASE NOTE: Extra leather or fabric may be required for composite panel testing. Additionally, you may be required to send a small quantity of your adhesive if it is not stocked at Skandia. We will make every effort to stock your glue.



# 16G Replacement Dress Cover Checklist

Flammability Testing & Certification

## Step 5: Items Required to Complete Fire-Blocking - continued

### IS PADDING OR BATTING/MUSLIN USED ON SEATING SURFACES?

Only .25" padding/batting can be used on the OLA bottom cushion.

#### IF YES, HOW IS IT HELD IN PLACE?

Yes      No                                      Glued              Placed              Stitched at seams              Quilted to dress cover

### IF FIREBLOCKING MATERIAL IS BEING USED, HOW IS IT USED?

- Glued on seating surface only
- Placed on seating surface only
- Fully Encapsulated with stitched seams
- Fully Encapsulated with glued seams
- Fully Encapsulated and bonded to foam

## Step 6: Production Drawings

If the original production drawings or the original report exist they must be sent either digitally or physically to Skandia.

### DO YOU HAVE A COPY OF THE ORIGINAL REPORT OR COPIES OF THE ORIGINAL PRODUCTION DRAWINGS?

Yes      No      If yes, please provide accordingly

### ORIGINAL FOAM ASSEMBLY DRAWING NUMBERS BELOW

## Step 7: Seam Closure

See example images and enter corresponding number on next page.

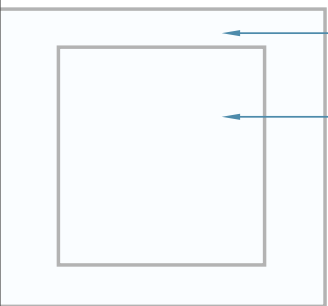
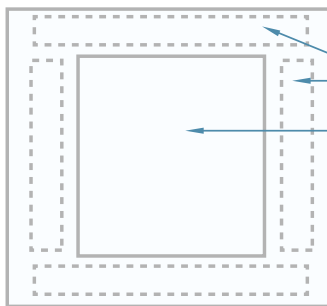
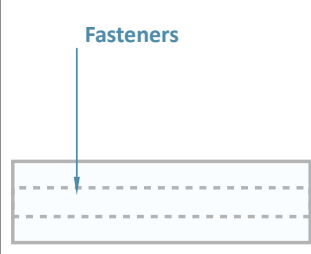
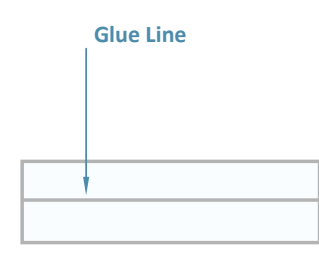
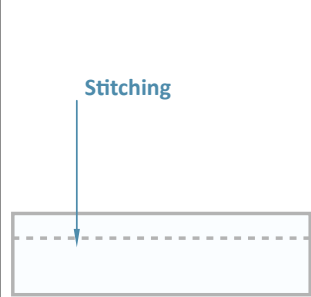
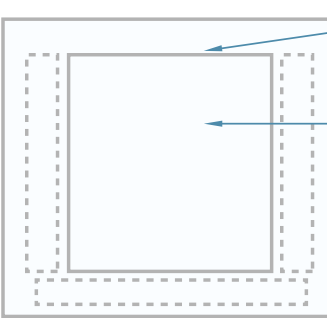
<p><b>Glued Window Pane #1</b></p>  <p>Dress Cover</p> <p>Close out Material</p> <p>Black view of back or bottom cushion. Dress cover bonds to a close out in window pane style with adhesive.</p>	<p><b>Fastened Window Pane #2</b></p>  <p>Dress Cover</p> <p>Fasteners</p> <p>Close out Material</p> <p>Black view of back or bottom cushion. Dress cover fastens to the close out in window pane style.</p>
<p><b>Fastened Side Seam #3</b> End view</p>  <p>Fasteners</p>	<p><b>Glued Side Seam #4</b> End View</p>  <p>Glue Line</p>
<p><b>Stitched Side Seam #5</b> End View</p>  <p>Stitching</p>	<p><b>Flap Closure #6</b></p>  <p>Stitching</p> <p>Flap</p> <p>Dress Cover stitched on one side with remaining three sides bonded or fastened.</p>



# 16G Replacement Dress Cover Checklist

Flammability Testing & Certification

## Step 7: Seam Closure - continued

See example images and enter corresponding number on next page.

### **SINGLE PASSENGER SEAT SEAM CLOSURE:**

BACK Bottom If "window pane", what is the close-out material?

### **DOUBLE PASSENGER SEAT SEAM CLOSURE:**

BACK Bottom If "window pane", what is the close-out material?

### **DIVAN SEAT SEAM CLOSURE:**

BACK Bottom If "window pane", what is the close-out material?

### **LAV SEAT SEAM CLOSURE:**

BACK Bottom If "window pane", what is the close-out material?

### **JUMP-SEAT SEAM CLOSURE:**

BACK Bottom If "window pane", what is the close-out material?

### **HEADREST SEAM CLOSURE:**

If "window pane", what is the close-out material?

### **LEGREST/FOOTREST SEAM CLOSURE:**

If "window pane", what is the close-out material?



# 16G Replacement Dress Cover Checklist

Flammability Testing & Certification

## Step 8: Matrix for Production Articles

This section of the form deals with production information. Fill in vendors and part numbers, then select the appropriate box for each specimen with an X.

### DRESS COVER

Vendor	Part #						Invoices or packing slips enclosed?
Pax Seats	Divan	Jump Seat	Lav Seat	Head Rest	Foot Rest	Flame Treatment	

### DRESS COVER

Vendor	Part #						Invoices or packing slips enclosed?
Pax Seats	Divan	Jump Seat	Lav Seat	Head Rest	Foot Rest	Flame Treatment	

### DRESS COVER

Vendor	Part #						Invoices or packing slips enclosed?
Pax Seats	Divan	Jump Seat	Lav Seat	Head Rest	Foot Rest	Flame Treatment	

### FOAM

Vendor	Part #						Invoices or packing slips enclosed?
Pax Seats	Divan	Jump Seat	Lav Seat	Head Rest	Foot Rest	Flame Treatment	

### FOAM

Vendor	Part #						Invoices or packing slips enclosed?
Pax Seats	Divan	Jump Seat	Lav Seat	Head Rest	Foot Rest	Flame Treatment	

### FOAM

Vendor	Part #						Invoices or packing slips enclosed?
Pax Seats	Divan	Jump Seat	Lav Seat	Head Rest	Foot Rest	Flame Treatment	



# 16G Replacement Dress Cover Checklist

Flammability Testing & Certification

## Step 8: Matrix for Production Articles - continued

This section of the form deals with production information. Fill in vendors and part numbers, then select the appropriate box for each specimen with an X.

### SCRIM-BACKED FOAM

Vendor		Part #					Invoices or packing slips enclosed?	
Pax Seats	Divan	Jump Seat	Lav Seat	Head Rest	Foot Rest	Flame Treatment		

### BATTING

Vendor		Part #					Invoices or packing slips enclosed?	
Pax Seats	Divan	Jump Seat	Lav Seat	Head Rest	Foot Rest	Flame Treatment		

### MUSLIN

Vendor		Part #					Invoices or packing slips enclosed?	
Pax Seats	Divan	Jump Seat	Lav Seat	Head Rest	Foot Rest	Flame Treatment		

### FIRE BLOCKER

Vendor		Part #					Invoices or packing slips enclosed?	
Pax Seats	Divan	Jump Seat	Lav Seat	Head Rest	Foot Rest	Flame Treatment		

### ADHESIVE

Vendor		Part #					Invoices or packing slips enclosed?	
Pax Seats	Divan	Jump Seat	Lav Seat	Head Rest	Foot Rest	Flame Treatment		

### FASTENER

Vendor		Part #					Invoices or packing slips enclosed?	
Pax Seats	Divan	Jump Seat	Lav Seat	Head Rest	Foot Rest	Flame Treatment		

### FASTENER

Vendor		Part #					Invoices or packing slips enclosed?	
Pax Seats	Divan	Jump Seat	Lav Seat	Head Rest	Foot Rest	Flame Treatment		





# 16G Replacement Dress Cover Checklist

Flammability Testing & Certification

## Step 8: Matrix for Production Articles - continued

This section of the form deals with production information. Fill in vendors and part numbers, then select the appropriate box for each specimen with an X.

### FASTENER

Vendor		Part #					Invoices or packing slips enclosed?	
Pax Seats	Divan	Jump Seat	Lav Seat	Head Rest	Foot Rest	Flame Treatment		

### CLOSE-OUT FABRIC

Vendor		Part #					Invoices or packing slips enclosed?	
Pax Seats	Divan	Jump Seat	Lav Seat	Head Rest	Foot Rest	Flame Treatment		

### ADHESIVE FASTENER

Vendor		Part #					Invoices or packing slips enclosed?	
Pax Seats	Divan	Jump Seat	Lav Seat	Head Rest	Foot Rest	Flame Treatment		

### OTHER

Vendor		Part #					Invoices or packing slips enclosed?	
Pax Seats	Divan	Jump Seat	Lav Seat	Head Rest	Foot Rest	Flame Treatment		

Item Material

### OTHER

Vendor		Part #					Invoices or packing slips enclosed?	
Pax Seats	Divan	Jump Seat	Lav Seat	Head Rest	Foot Rest	Flame Treatment		

Item Material

### COMMENTS

## Step 9: Single Seats Dimensions

Enter in all seat dimensions according to the reference image provided.

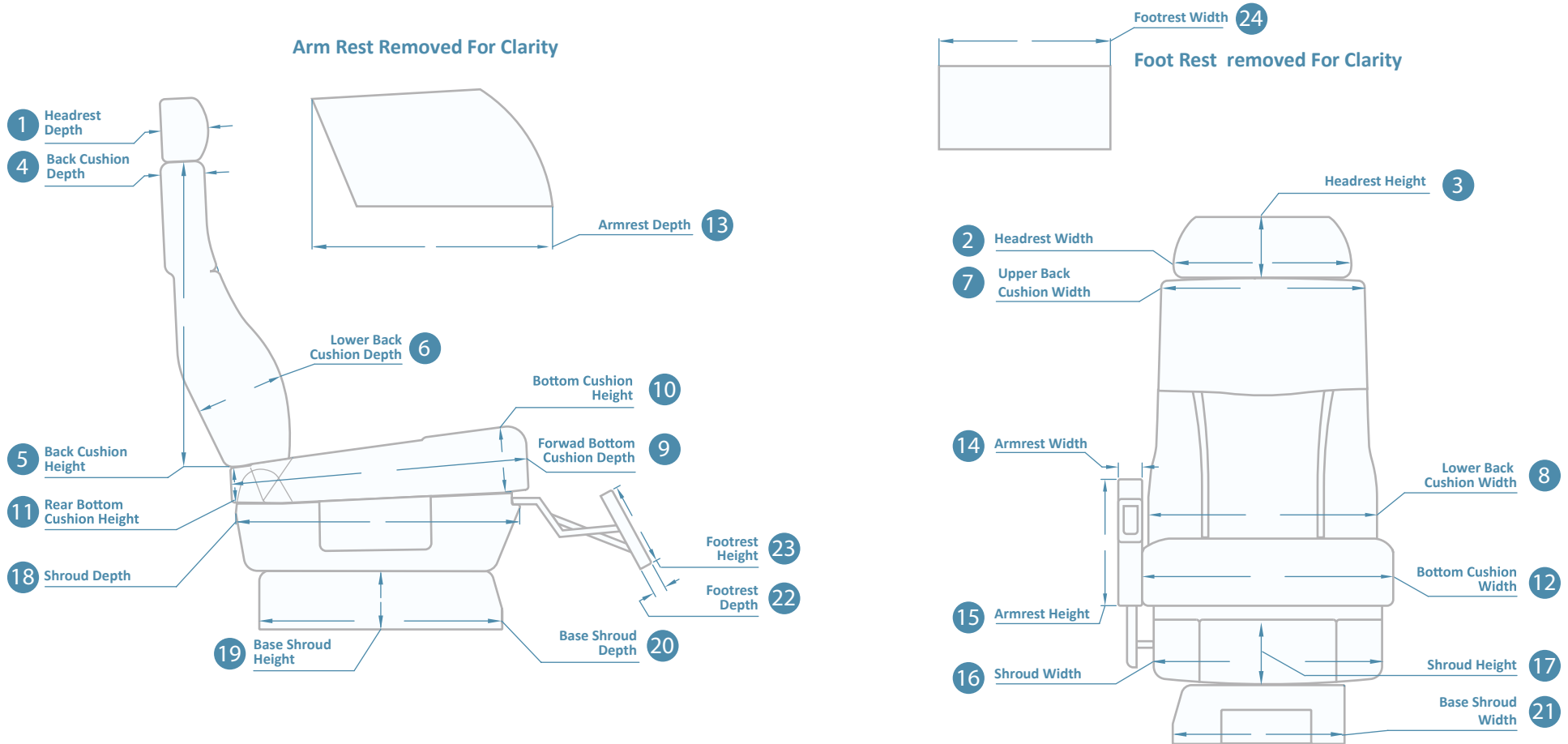



# 16G Replacement Dress Cover Checklist

Flammability Testing & Certification

## Step 9: Single Seats Dimensions - continued

Enter in all seat dimensions according to the reference image provided on page 10.

**1: HEADREST DEPTH**

**2: HEADREST WIDTH**

**3: HEADREST HEIGHT**

**4: BACK CUSHION DEPTH**

**5: BACK CUSHION HEIGHT**

**6: LOWER BACK CUSHION HEIGHT**

**7: UPPER BACK CUSHION WIDTH**

**8: LOWER BACK CUSHION WIDTH**

**9: FORWARD CUSHION DEPTH**

**10: BOTTOM CUSHION HEIGHT**

**11: REAR CUSHION HEIGHT**

**12: BOTTOM CUSHION WIDTH**

**13: ARMREST DEPTH**

**14: ARMREST WIDTH**

**15: ARMREST HEIGHT**

**16: SHROUD WIDTH**

**17: SHROUD HEIGHT**

**18: SHROUD DEPTH**

**19: BASE SHROUD HEIGHT**

**20: BASE SHROUD DEPTH**

**21: BASE SHROUD WIDTH**

**22: FOOTREST DEPTH**

**23: FOOTREST HEIGHT**

**24: FOOTREST WIDTH**

## Step 10: Double Seats Dimensions

Enter in all seat dimensions on page 13 according to the reference image provided below.

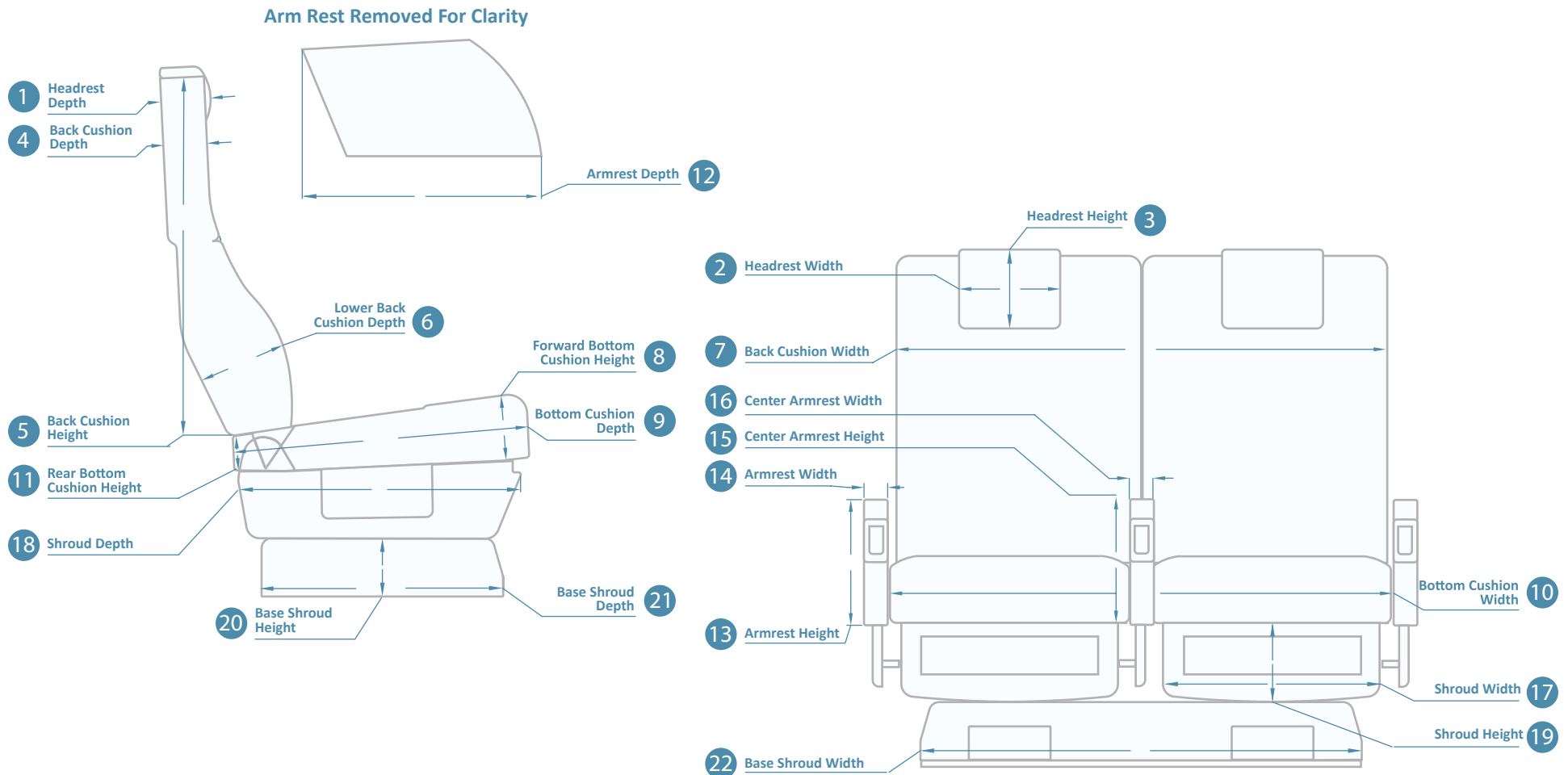



# 16G Replacement Dress Cover Checklist

Flammability Testing & Certification

## Step 10: Double Seats Dimensions - continued

Enter in all seat dimensions according to the reference image provided on page 12.

**1: HEADREST DEPTH**

**2: HEADREST WIDTH**

**3: HEADREST HEIGHT**

**4: BACK CUSHION DEPTH**

**5: BACK CUSHION HEIGHT**

**6: LOWER BACK CUSHION DEPTH**

**7: BACK CUSHION WIDTH**

**8: FORW. BOTTOM CUSHION HEIGHT**

**9: BOTTOM CUSHION DEPTH**

**10: BOTTOM CUSHION WIDTH**

**11: REAR BOTTOM CUSHION HEIGHT**

**12: ARMREST DEPTH**

**13: ARMREST HEIGHT**

**14: ARMREST WIDTH**

**15: CENTER ARMREST HEIGHT**

**16: CENTER ARMREST WIDTH**

**17: SHROUD WIDTH**

**18: SHROUD DEPTH**

**19: SHROUD HEIGHT**

**20: BASE SHROUD HEIGHT**

**21: BASE SHROUD DEPTH**

**22: BASE SHROUD WIDTH**

## Step 11: Divan Seats Dimensions

Enter in all seat dimensions on page 15 according to the reference image provided below.

Arm Rest Removed For Clarity

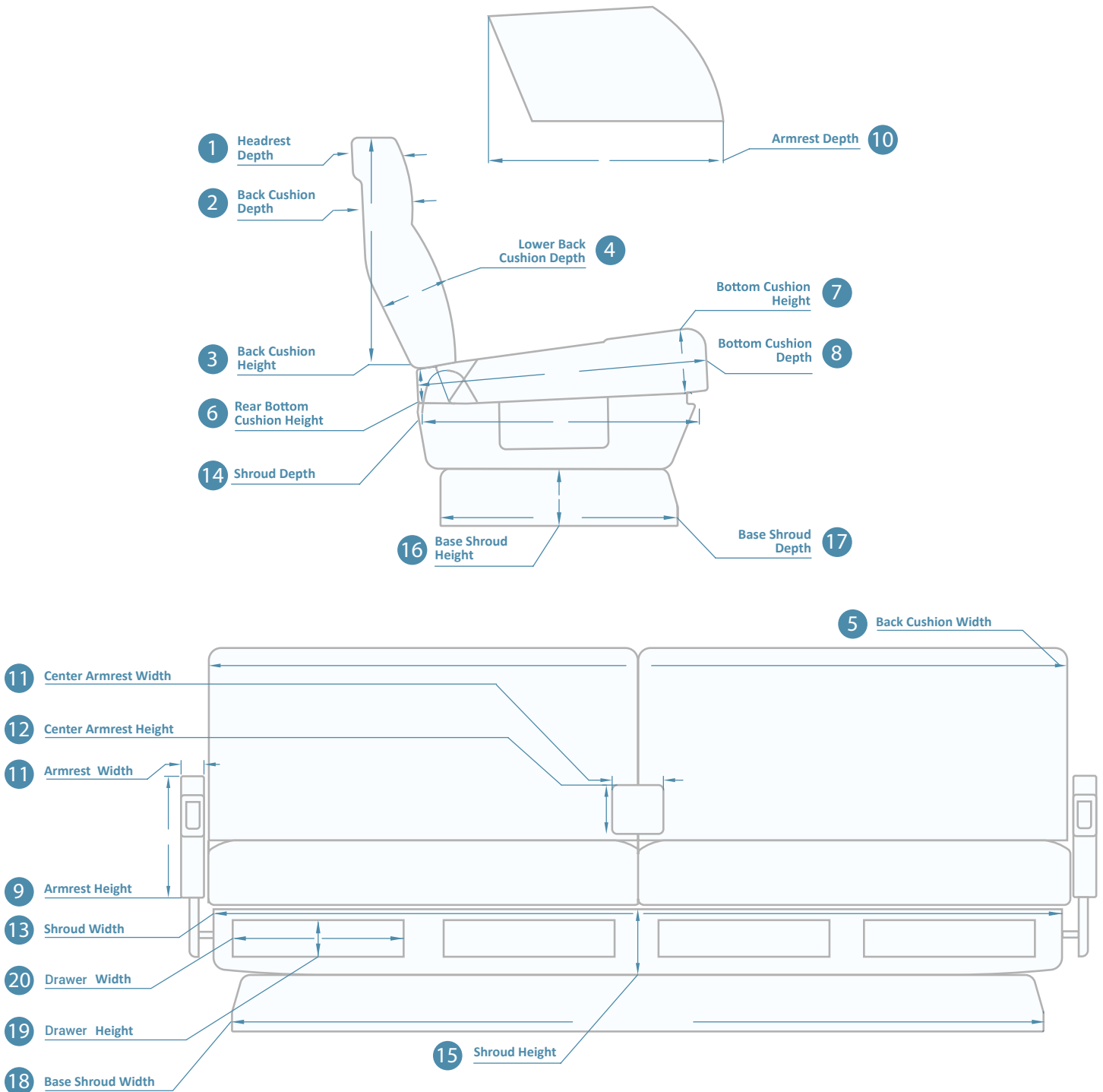



# 16G Replacement Dress Cover Checklist

Flammability Testing & Certification

## Step 11: Divan Seats Dimensions - continued

Enter in all seat dimensions according to the reference image provided on page 12.

**1: HEADREST DEPTH**

**2: BACK CUSHION DEPTH**

**3: BACK CUSHION HEIGHT**

**4: LOWER BACK CUSHION DEPTH**

**5: BACK CUSHION WIDTH**

**6: REAR BOTTOM CUSHION HEIGHT**

**7: BOTTOM CUSHION HEIGHT**

**8: BOTTOM CUSHION DEPTH**

**9: ARMREST HEIGHT**

**10: ARMREST DEPTH**

**11: ARMREST WIDTH**

**12: CENTER ARMREST HEIGHT**

**13: SHROUD WIDTH**

**14: SHROUD DEPTH**

**15: SHROUD HEIGHT**

**16: BASE SHROUD HEIGHT**

**17: BASE SHROUD DEPTH**

**18: BASE SHROUD WIDTH**

**19: DRAWER HEIGHT**

**20: DRAWER WIDTH**

## Step 12: Universal Seats Dimensions

Enter in all seat dimensions on page 17 according to the reference image provided below.

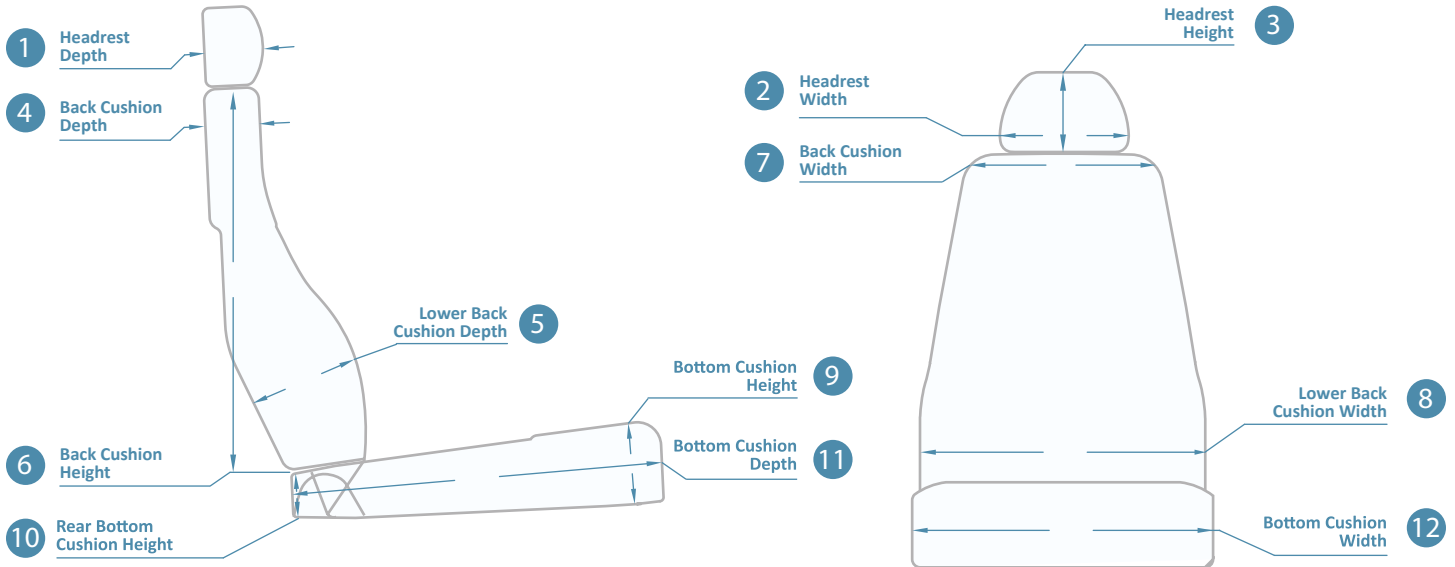

**1: HEADREST DEPTH**

**2: HEADREST WIDTH**

**3: HEADREST HEIGHT**

**4: BACK CUSHION DEPTH**

**5: LOWER BACK CUSHION DEPTH**

**6: BACK CUSHION HEIGHT**

**7: BACK CUSHION WIDTH**

**8: LOWER BACK CUSHION DEPTH**

**9: BOTTOM CUSHION HEIGHT**

**10: REAR BOTTOM CUSHION HEIGHT**

**11: BOTTOM CUSHION DEPTH**

**12: BOTTOM CUSHION WIDTH**

**OTHER**

**OTHER**

**OTHER**



## Step 13: Divan Substrate and/or Foam Build-Ups

Please list all materials used in production including substrates and adhesives. The information provided will be used for composite panel testing. Please include part number and thickness of materials.

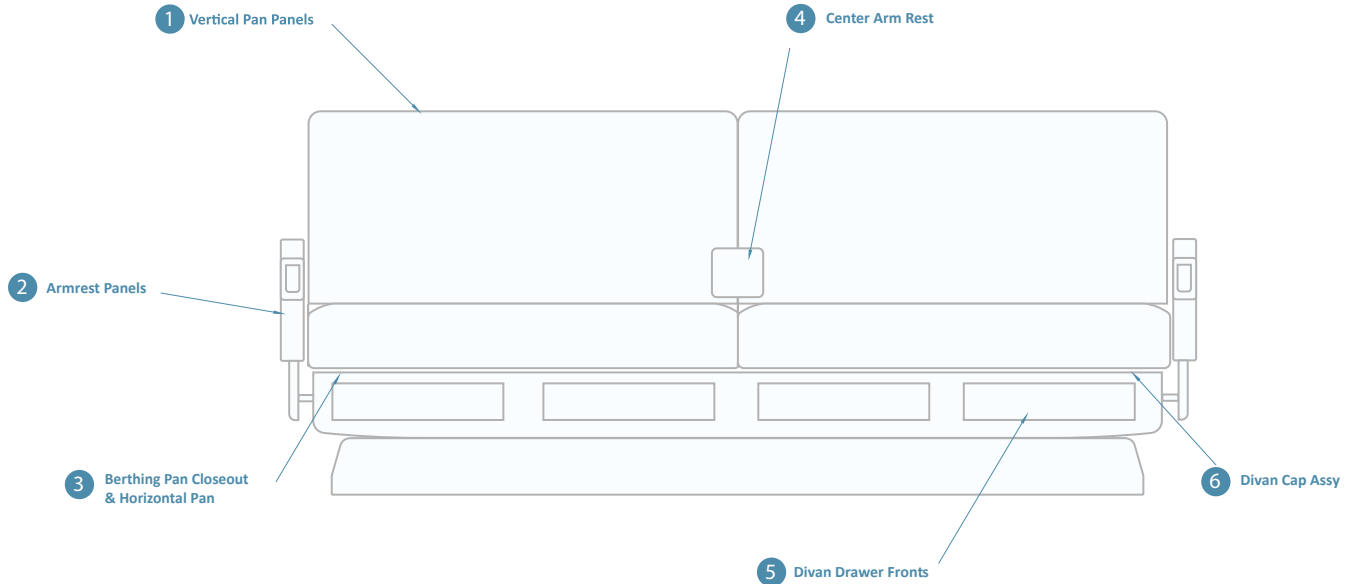

**1: VERTICAL PANELS**

**2: ARM REST**

**3: BERTHING PAN CLOSEOUT & HORIZONTAL PAN**

**4: CENTER ARM REST**

**5: DIVAN DRAWER FRONTS**

**6: DIVAN CAP ASSEMBLY**

## DRESS COVERING

## Step 14: Double Seat Composite Panel Production Buildup

Please list all materials used in production including substrates and adhesives. The information provided will be used for composite panel testing. Please include part number and thickness of materials.

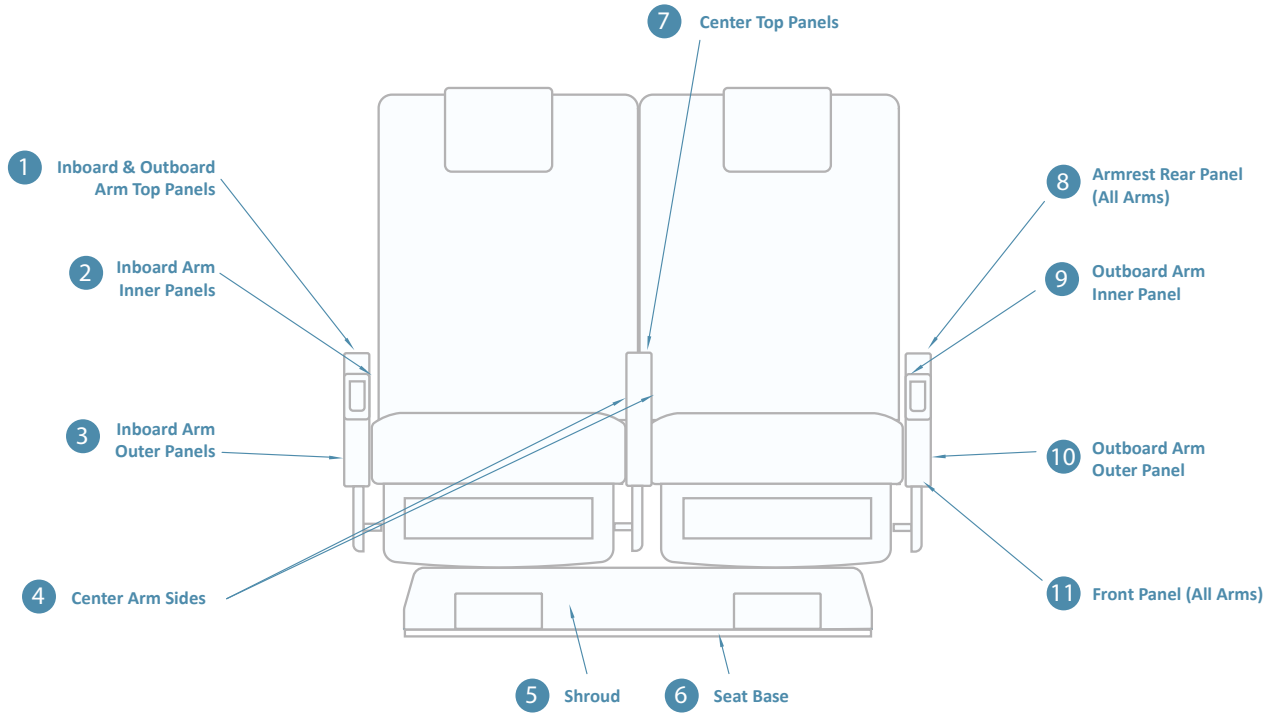

**1: INBOARD & OUTBOARD ARM TOP PANELS**

**2: INBOARD ARM INNER PANELS**

**3: INBOARD ARM OUTER PANELS**

**4: CENTER ARM SIDES**

**5: SHROUD**

**6: SEAT BASE**



# 16G Replacement Dress Cover Checklist

Flammability Testing & Certification

---

## Step 14: Double Seat Composite Panel Production Buildup - continued

Please list all materials used in production including substrates and adhesives. The information provided will be used for composite panel testing. Please include part number and thickness of materials.

**7: CENTER TOPS PANELS**

**8: ARMREST REAR PANEL** (ALL ARMS)

**9: OUTBOARD ARM INNER PANEL**

**10: OUTBOARD ARM OUTER PANEL**

**11: FRONT PANEL** (ALL ARMS)

**DRESS COVERING**

## Step 15: Single Seat Composite Panel Production Buildup

Please list all materials used in production including substrates and adhesives. The information provided will be used for composite panel testing. Please include part number and thickness of materials.

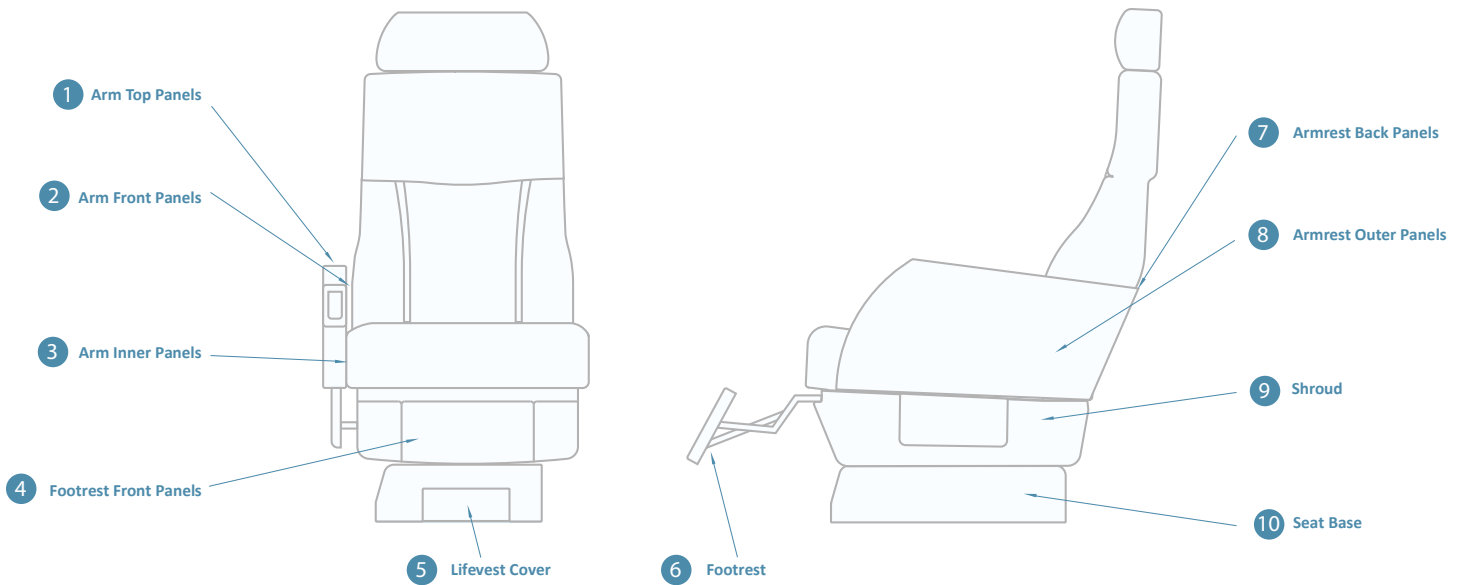

**1: ARM TOP PANELS**

**2: ARM FRONT PANELS**

**3: ARM INNER PANELS**

**4: FOOTREST FRONT PANEL**

**5: LIFEVEST COVER**

**6: FOOTREST**



# 16G Replacement Dress Cover Checklist

Flammability Testing & Certification

---

## Step 15: Single Seat Composite Panel Production Buildup - continued

Please list all materials used in production including substrates and adhesives. The information provided will be used for composite panel testing. Please include part number and thickness of materials.

**7: ARMREST BACK PANELS**

**8: ARMREST OUTER PANELS**

**9: SHROUD**

**10: SEAT BASE**

**DRESS COVERING**

## Step 16: Seat Location

We need to know the placement of each seat in the aircraft along with the serial number and part number of each seat on the aircraft. Please include part number and thickness of materials.

**Example**

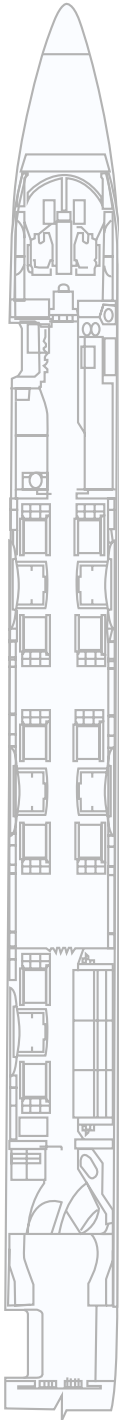

**Please fill in accordingly**



## Step 17: Hook and Loop Placement

Referring back to Page 3, it is very important to simulate the placement of any hook and loop attachment strips that may attach either back or bottom assemblies to the seat frame. Please document dimensional placement. Note which direction is the front of the cushion and if 1" or 2" fasteners are being used along with length of fastener attachment strips. Please fill this out for each type of seat being tested.

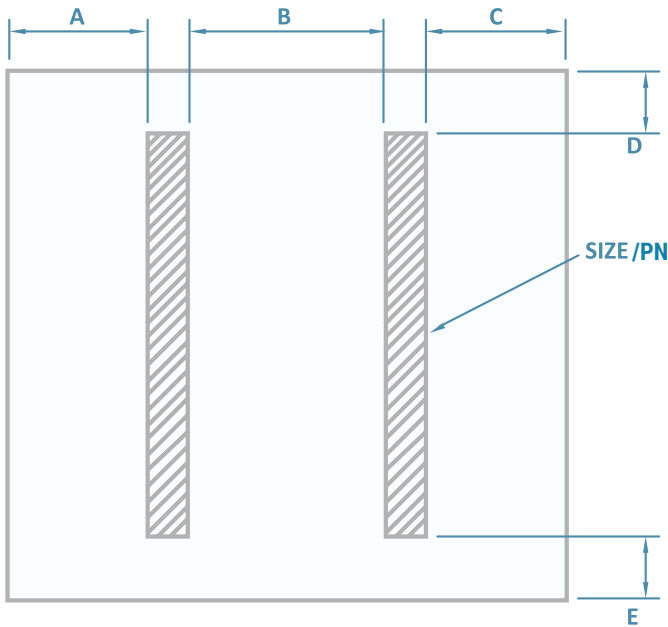

Back Cushion

### BACK CUSHION

A                      B                      C

D                      E                      Direction (optional)

Fastener Length                      Fastener Part #

### BOTTOM CUSHION

F                      G                      H

F                      F                      Direction (optional)

Fastener Length                      Fastener Part #

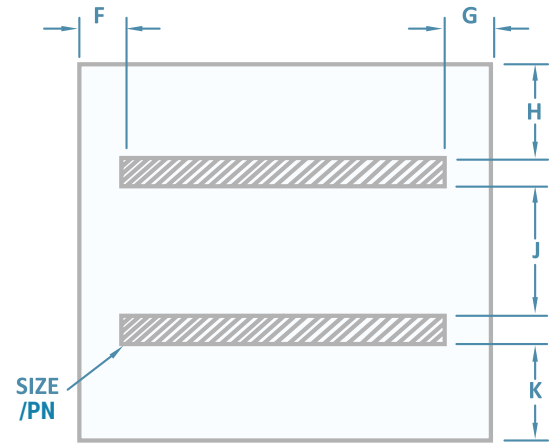

Bottom Cushion

### IS HOOK OR LOOP BEING USED FOR ATTACH STRIPS ON CUSHION?

Yes      No

### IS THE HOOK AND LOOP NEW OR EXISTING?

New      Existing

### IS THE ATTACH STRIP FASTENER ON THE SEAT FRAME NEW OR EXISTING?

New      Existing